

SIEMENS

7⁴⁵¹



Burner Controls

LFL1...

Burner controls

- For gas, oil or dual-fuel forced draft burners of medium to high capacity
- For multistage or modulating burners in intermittent operation
- With checked air damper control
- Flame supervision
 - with UV detectors QRA...
 - and ionization probe

The LFL1... and this Data Sheet are intended for use by OEMs which integrate the burner controls in their products!

Use

- Control and supervision of forced draft burners of direct spark flame or interrupted pilot construction
- For medium to high capacity
- For intermittent operation (at least one controlled shutdown every 24 hours)
- For universal use with multistage or modulating burners
- For use with dual-fuel burners
- For use with stationary air heaters
- Burner control conforming to DIN EN 230: 2005 and DIN EN 298: 2004

The difference between 01 series and 02 series is the duration of the safety time for the pilot burner of burners equipped with pilot gas valves.

For atmospheric burners of high capacity, use the LFL1.638.

For burner controls suited for continuous operation, refer to Data Sheet N7785 (LGK16...).

Warning notes



To avoid injury to persons, damage to property or the environment, the following warning notes should be observed!

Do not open, interfere with or modify the unit!

- All activities (mounting, installation and service work, etc.) must be performed by qualified staff
- Before performing any wiring changes in the connection area of the LFL1..., completely isolate the unit from the mains supply (all-polar disconnection)
- Ensure protection against electric shock hazard by providing adequate protection for the burner control's connection terminals
- Each time work has been carried out (mounting, installation, service work, etc.), check to ensure that wiring is in an orderly state and make the safety checks as described in «Commissioning notes»
- Press the lockout reset button only manually (apply a force of no more than 10 N), without using any tools or pointed objects
- **Do not press the lockout reset button on the unit or the remote lockout reset button for more than 10 seconds since this damages the lockout relay in the unit**
- Fall or shock can adversely affect the safety functions. Such units must not be put into operation, even if they do not exhibit any damage
- In the case of flame supervision with UV detectors QRA..., it should be noted that sources of radiation such as halogen lamps, welding equipment, special lamps, ignition sparks, as well as X-rays and gamma radiation, can produce erroneous flame signals

Mounting notes

- Ensure that the relevant national safety regulations are complied with
- **An ignited UV tube is a source of UV radiation!** In case of flame supervision by means of flame detectors, the detectors must be placed such that there is **no direct visual contact** between them. If this is not observed, there is a risk of loss of safety functions

Installation notes

- Always run the high-voltage ignition cables separately while observing the greatest possible distance to the unit and to other cables
- Do not mix up live and neutral conductors

Electrical connection of flame detectors

It is important to achieve practically disturbance- and loss-free signal transmission:

- Never run the detector cable together with other cables
 - Line capacitance reduces the magnitude of the flame signal
 - Use a separate cable
- Observe the maximum permissible detector cable lengths (refer to «Technical data»)
- 2 UV detectors QRA... can be connected in parallel (observe the warning note)
- In connection with the QRA..., earthing of terminal 22 is mandatory
- The ionization probe is not protected against electric shock hazard
- Locate the ignition electrode and ionization probe such that the ignition spark cannot arc over to the ionization probe (risk of electrical overloads)
- Supervision with both ionization probe and UV detector QRA... is possible, but for safety reasons – with the exception of the second safety time «t₉» – only 1 flame detector may be active at a time. At the end of the second safety time, 1 of the detectors must be inactive, however, that is, the detected flame must have extinguished, e.g. by switching off the ignition valve via terminal 17

Commissioning notes

- When commissioning the plant or when doing maintenance work, make the following safety checks:

	Safety check to be carried out	Anticipated response
a)	Burner start with flame detector darkened	Lockout at the end of «TSA»
b)	Burner start with flame detector exposed to extraneous light	Lockout after no more than 40 seconds
c)	Burner operation with simulated loss of flame; for that purpose, darken the flame detector in operation and maintain that state (not possible with ionization)	Lockout

Engineering notes

- Install switches, fuses, earthing, etc., in compliance with local regulations
- Decisive for the connection of the valves and other plant components is the plant diagram provided by the burner manufacturer

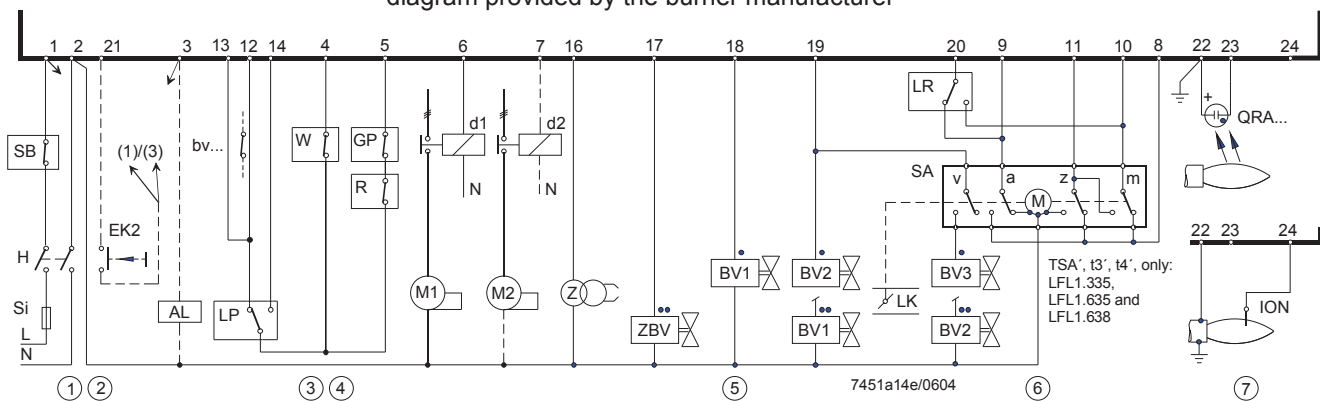

①	Connect safety limit thermostat in the line (manual reset, e.g. «SB»)
②	Remote reset When remote reset button «EK2» is connected between terminal 21 and - terminal 3, only remote reset is possible - terminal 1, both remote emergency shutdown and remote reset are possible
③	Required switching capacities - of the switching devices connected between terminals 12 and 4 (refer to «Technical data») - of the switching devices connected between terminals 4 and 14 (refer to «Technical data») - depending on the loads applied to terminals 16...19 (refer to «Technical data»)
④	Air pressure supervision If the air pressure is not monitored with air pressure switch «LP», terminal 4 must be connected to terminal 12, and terminal 6 to terminal 14. Terminal 13 is not used. Control contacts of the other devices in the burner installation – if series-connected – are to be connected as follows: - To terminal 4 or 5 → contacts which must be closed from startup to controlled shutdown → otherwise no start or shutdown - To terminal 12 → contacts which must only be closed on startup → otherwise no start - To terminal 14 → contacts which must be closed at the beginning of the preignition time at the latest, and which must stay closed until controlled shutdown occurs → otherwise lockout; this applies to both long and short preignition
⑤	<ul style="list-style-type: none"> Connection of fuel valves with direct spark flame burners. With 2-stage burners, «BV2» is connected in place of «BV3» •• Connection of fuel valves with interrupted pilot burners Direct connection of a fuel valve to terminal 20 is only permitted - in plants with a main shutoff valve on the mains side (safety shutoff valve), which is controlled by terminal 18 or 19, and - if 2-stage valves are used, provided they fully close when the first stage, controlled by terminal 18 or 19, is switched off
⑥	For additional examples of air damper control, refer to «Connection examples». In the case of actuators with no end switch «z» for the fully CLOSED position of the air damper, terminal 11 must be connected to terminal 10 → otherwise no burner start.
⑦	Simultaneous use of ionization and UV supervision is possible

Standards and certificates



Conformity to EEC directives
 - Electromagnetic compatibility EMC (immunity)
 - Directive for gas appliances

2004/108/EC
 2009/142/EC



ISO 9001: 2008
 Cert. 00739



ISO 14001: 2004
 Cert. 38233

Certified complete with plug-in base and flame detector:

Type reference	SA	GL	DVGW	DIN G9raft	UL	TÜV CERT	The Association of Component Manufacturers	TÜV
LFL1.122	●	---	●	●	●	●	●	●
LFL1.133	●	---	●	●	---	●	---	●
LFL1.322	●	---	●	●	●	●	●	●
LFL1.333	●	---	●	●	●	●	---	●
LFL1.335	●	●	●	●	●	●	●	●
LFL1.622	●	---	●	●	●	●	●	●
LFL1.635	●	---	●	●	●	●	●	●
LFL1.638	●	---	●	---	●	●	---	●

- **Identification code to EN 298**

- LFL1.638

- All other types (except LFL1.148)

A B L L X N

F B L L X N

Life cycle

Burner controls has a designed lifetime* of 250,000 burner startup cycles which, under normal operating conditions in heating mode, correspond to approx. 10 years of usage (starting from the production date given on the type field). This lifetime is based on the endurance tests specified in standard EN 298 and the table containing the relevant test documentation as published by the European Association of Component Manufacturers (Afecor) (www.afecor.org).

The designed lifetime is based on use of the burner controls according to the manufacturer's Data Sheet. After reaching the designed lifetime in terms of the number of burner startup cycles, or the respective time of usage, the burner control is to be replaced by authorized personnel.

* The designed lifetime is not the warranty time specified in the Terms of Delivery

Disposal notes



The unit contains electrical and electronic components and must not be disposed of together with domestic waste.
 Local and currently valid legislation must be observed.

Mechanical design

LFL1...	<ul style="list-style-type: none"> - Plug-in design - Exchangeable unit fuse (including spare fuse)
Housing	<ul style="list-style-type: none"> - Made of impact-proof and heat-resistant black plastic - Lockout reset button with viewing window showing <ul style="list-style-type: none"> – the fault signal lamp – the lockout indicator <ul style="list-style-type: none"> - coupled to the program spindle - visible in the transparent lockout reset button - uses easy-to-remember symbols to indicate the type of fault and the time lockout occurred

Type summary

Switching times are given in seconds, in the burner startup sequence, valid for 50 Hz mains frequency. At 60 Hz, switching times are about 17 % shorter.

	Flash steam generators	Flash steam generators	D (incl. stationary air heaters) F	A D	GB	F I	B NL ²⁾	Large atmospheric burners
	LFL1.122 ¹⁾ 02 series	LFL1.133 ¹⁾ 02 series	LFL1.322 ¹⁾ 02 series	LFL1.333 ¹⁾ 02 series	LFL1.335 ¹⁾ 01 series	LFL1.622 ¹⁾ 02 series	LFL1.635 ¹⁾ 01 series	LFL1.638 01 series
t1	10	9	36	31	37	65	66	66
TSA	2	3	2	3	2.5	2	2.5	2.5
TSA'	2	3	2	3	5	2	5	5
t3	4	3	4	6	5	4	5	5
t3'	4	---	4	6	2.5	4	2.5	2.5
t4	6	6	10	11.5	12.5	10	12.5	12.5
t4'	6	---	10	11.5	15	10	15	15
t5	4	3	10	11.5	12.5	10	12.5	12.5
t6	10	14.5	12	18	15	12	15	15
t7	2	3	2	3	2.5	2	2.5	2.5
t8	30	29	65	69	74	95	103	103
t9	2	3	2	3	5	2	5	7.5
t10	6	6	8	11.5	10	8	10	10
t11	Optional							
t12	Optional							
t13	10	14.5	12	17	15	12	15	15
t16	4	3	4	6	5	4	5	5
t20	32	60	---	26	22	---	---	---

¹⁾ Available as AC 100...110 V versions; add type suffix «-110 V» when ordering

²⁾ Reversed polarity protection conforming to Dutch installation standard: AGM30

Burner control, without plug-in base see «Type summary»
Plug-in base not included in delivery, must be ordered as a separate item!

Connection accessories for medium-capacity burner controls see Data Sheet N7230

- Plug-in base **AGM410490550** with Pg11 thread for cable entry glands

- Plug-in base **AGM14.1** with M16 thread for cable entry glands

Flame detectors

- Flame detectors **QRA...**

refer to Data Sheet N7712

- **Ionization probe**

to be supplied by thirds

Test unit KF8806 for burner control

see Operating Instructions B7987

- For simulating faults

- For checking the pull-in and drop-out values of the flame relay in the case of flame supervision with flame detector QRA... or ionization probe

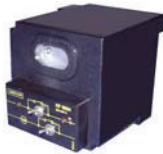

Test unit KF8804 for burner control

- Tool to assist startup, with the possibility of program stop and measurement of the flame current



Reversed polarity protection AGM30 for Netherlands

Technical data

General unit data LFL1...	Mains voltage	AC 230 V –15 / +10 % AC 115 V –15 / +10 %	
	Mains frequency	50...60 Hz ±6 %	
	Unit fuse (built-in)	T6.3H250V to DIN EN 60 127	
	Primary fuse (external)	max. 10 A (slow)	
	Weight	approx. 1,000 g	
	Power consumption	approx. AC 3.5 VA	
	Mounting position	optional	
	Degree of protection	IP 40, when built in, with the exception of the connection area (terminal base)	
	Safety class	II	
	Perm. input current at terminal 1	max. 5 A continuously (peaks 20 A / 20 ms)	
	Perm. load on control terminals 3, 6, 7, 9...11, 15...20	max. 4 A continuously (peaks 20 A / 20 ms)	
	Required switching capacity of switching devices		
	- Between terminals 4 and 5	1 A, AC 250 V	
	- Between terminals 4 and 12	1 A, AC 250 V	
	- Between terminals 4 and 14	min. 1 A, AC 250 V depending on the load on terminals 16...19	
	Environmental conditions	Storage	DIN EN 60721-3-1
		Climatic conditions	class 1K3
Mechanical conditions		class 1M2	
Temperature range		-20...+60 °C	
Humidity		< 95 % r.h.	
Transport		DIN EN 60721-3-2	
Climatic conditions		class 2K3	
Mechanical conditions		class 2M2	
Temperature range		-20...+60 °C	
Humidity		< 95 % r.h.	
Operation		DIN EN 60 721-3-3	
Climatic conditions		class 3K3	
Mechanical conditions		class 3M3	
Temperature range		-20...+60 °C	
Humidity		< 95 % r.h.	



Warning!

**Condensation, formation of ice and ingress of water are not permitted!
If not observed, there is a risk of impairment of safety functions and of electric shock hazard.**

Flame supervision with ionization probe	Voltage at the ionization probe	
	- Operation	AC 330 V ±10 %
	- Test	AC 380 V ±10 %
	Short-circuit current	max. 0.5 mA
	Recommended range of measuring instrument	0...50 µA
	Perm. length of detector cable	
	- Normal cable, laid separately ²⁾	max. 80 m
	- Shielded cable	max. 140 m (e.g. high-frequency cable; shielding connected to terminal 22)
	Required detector current in operation	min. 6 µA
	Possible detector current in operation	max. 200 µA

Technical data (cont'd)

Flame supervision with flame detector QRA...

Supply voltage	
- Operation	AC 330 V \pm 10 %
- Test	AC 380 V \pm 10 %
Required detector current	min. 70 μ A
Possible detector current	
- Operation	max. 700 μ A
- Test	max. 1000 μ A ¹⁾
Perm. length of detector cable	
- Normal cable, laid separately ²⁾	max. 100 m
- Shielded cable	max. 200 m (e.g. high-frequency cable; shielding connected to terminal 22)

¹⁾ During the prepurge time with higher test voltage: Self-ignition and extraneous light test

²⁾ Multicore cable not permitted

Measuring circuit for detector current measurement

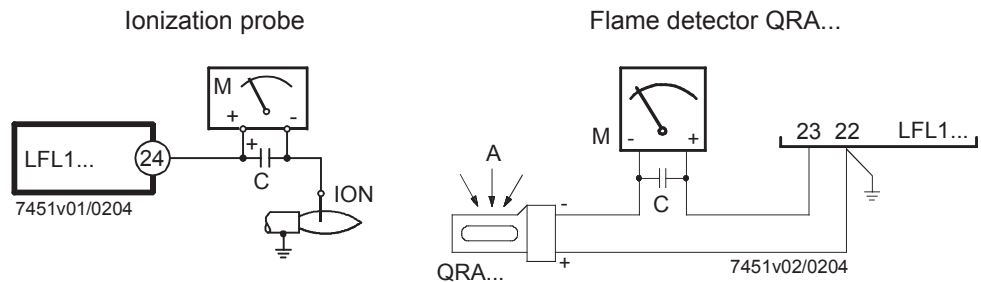

For detector currents, refer to «Technical data».

Legend

- C Electrolytic condenser 100...470 μ F; DC 10...25 V
- ION Ionization probe
- M Microammeter R_i max. 5,000 Ω

Function

2-stage direct spark flame burner

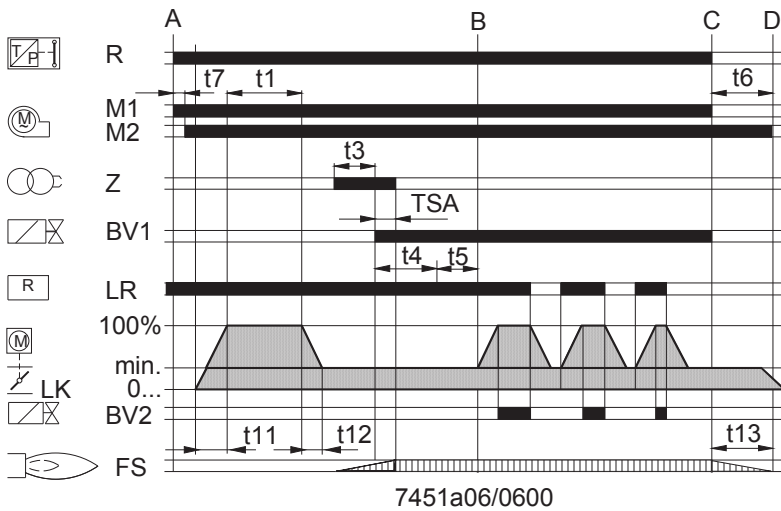

7451a06/0600

Legend

- BV... Fuel valve
- FS Flame signal amplifier
- LK Air damper
- LR Load controller
- M... Fan or burner motor
- R Control thermostat or pressurestat
- RV Modulating fuel valve
- Z Ignition transformer
- ZBV Pilot gas valve
- A Start command by «R»
- B Operating position of burner
- B-C Burner operation
- C Controlled shutdown
- C-D Sequence switch travels to start position «A», postpurgung
- D-A End of control sequence

Modulating direct spark flame burner

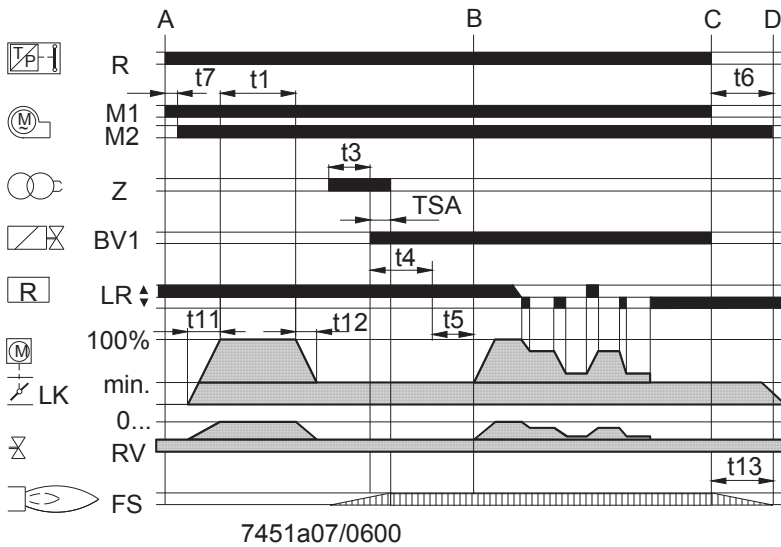

7451a07/0600

- t1 Pre-purge time with air damper fully open
- t3/t3' Pre-ignition time
- t4/t4' Interval «BV1-BV2» or «BV1-LR»
- t5 Interval between voltage at terminal 19 and terminal 20
- t6 Post-purge time
- t7 Interval between start command and voltage at terminal 7
- t9 2nd safety time with burners equipped with a pilot burner
- t11 Air damper's running time to the fully OPEN position
- t12 Air damper's running time to the low-fire position
- t13 Permissible afterburn time
- TSA/ Ignition safety time
- TSA' Ignition safety time

2-stage interrupted pilot burner

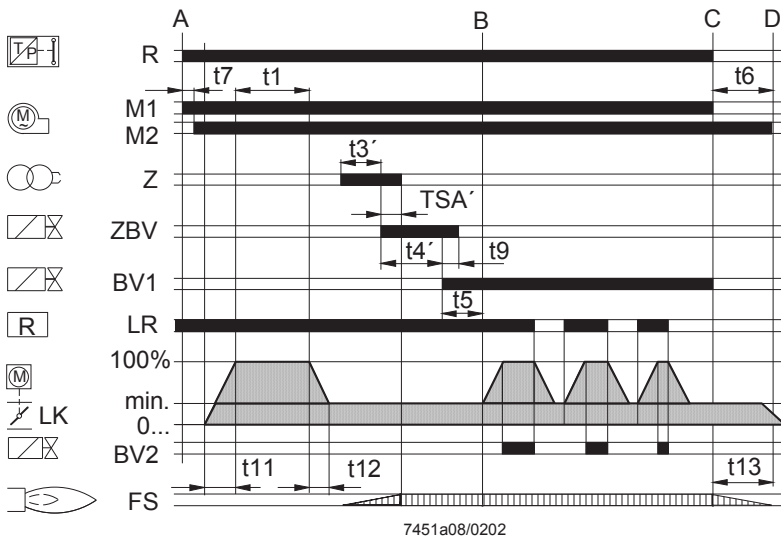

7451a08/0202

Function (cont'd)

General	<p>The following features enable the LFL1... to offer a high level of additional safety:</p> <ul style="list-style-type: none">- Detector and extraneous light test are resumed immediately on completion of the afterburn time «t13». Fuel valves that are not closed, or not fully closed, immediately initiate lockout on completion of the afterburn time «t13». The test will only be terminated when the prepurge time «t1» of the next startup sequence has elapsed.- The proper functioning of the flame supervision circuit is automatically checked during each startup phase of the burner.- During the postpurge time «t6», the control contacts for the release of fuel are checked to ensure they have not welded.- The built-in unit fuse protects the control contacts against overloads.
Control of the burner	<ul style="list-style-type: none">- Burner operation with or without postpurging- Fan motors with a current draw of up to 4 A can be connected directly → starting current max. 20 A (max. 20 ms)- Separate control outputs for one pilot valve, which will be shut on completion of the second safety time- Separate control outputs for the actuator's positioning directions «OPEN», «CLOSE» and «MIN»- Checked air damper control to ensure prepurging with the nominal amount of air- Checked positions:<ul style="list-style-type: none">- «CLOSED» or «MIN» on startup → low-fire position- «OPEN» at the start of prepurging- «MIN» on completion of prepurgingIf the actuator does not drive the air damper to the required position, the burner startup sequence will be stopped- 2 control outputs for the release of the second and third output stage, or load control- When load control is enabled, the control outputs for the actuator will galvanically be separated from the unit's control section- Connection facilities for<ul style="list-style-type: none">- remote lockout warning device- remote reset- remote emergency shutdown- With burner controls of the 01 series and direct spark flame burners, the safety time can be increased from 2.5 to 5 seconds by changing the circuitry (refer to «Connection examples»), provided the longer safety time conforms to local safety regulations
Flame supervision	<ul style="list-style-type: none">- With the ionization probe, in networks with earthed or nonearthed neutral conductor. For this kind of supervision, the flame supervision circuit is designed such that possible disturbances of the ionization current due to the ignition spark normally have no impact on the establishment of the flame signal. A short-circuit between ionization probe and burner ground causes loss of the flame signal- With UV detector QRA... (gas and oil burners)- Simultaneous use of ionization probe and UV detector QRA... (e.g. with interrupted pilot burners or gas-electrically ignited oil burners)
Preconditions for startup	<ul style="list-style-type: none">- If, on startup, the required input signals are not present, the burner control interrupts the startup sequence at the points marked by symbols and initiates lockout where required by safety regulations. The symbols used in this Data Sheet correspond to those on the burner control's lockout indicator.
Preconditions for burner startup	<ul style="list-style-type: none">- Burner control must be reset- Sequence switch must be in its start position → voltage at terminals 4 and 11 present- Air damper closed- End switch «z» for the «CLOSED» position must feed voltage from terminal 11 to terminal 8- The contacts of control thermostat or pressurestat «W» and other contacts of switching devices connected between terminal 12 and «LP» must be closed → e.g. control contact for the oil preheater's temperature- Terminal 4 must be live- The N.C. contact of the air pressure switch must be closed → «LP» test

Startup sequence

- A Start command delivered by «R»
- «R» closes the start control loop between terminals 4 and 5
 - The sequence switch starts running
 - Only prepurging, power is immediately fed to the fan motor connected to terminal 6
 - Pre- and postpurging; on completion of «t7», power is fed to the fan motor or flue gas fan connected to terminal 7
 - On completion of «t16», the control command to open the air damper is delivered via terminal 9
 - No power is fed to terminal 8 during the positioning time
 - The sequence switch continues its travel only after the air damper has fully opened

- t1 Prepurge time with air damper fully open
- During «t1», the correct functioning of the flame supervision circuit is tested
 - If test is not successful, the burner control will initiate lockout

Shortly after the start of «t1», the air pressure switch must change over from terminal 13 to terminal 14.
→ Otherwise lockout
→ Start of air pressure check

At the same time, terminal 14 must be live since the ignition transformer will be powered and the fuel released via this current path.

On completion of the prepurge time, the burner control will drive the air damper to the low-fire position via terminal 10, which is determined by the changeover point of auxiliary switch «m». During the positioning time, the sequence switch stops again. A short time later, the motor of the sequence switch will be switched to the control section of the burner control. This means that, from now on, positioning signals delivered to terminal 8 have no impact on the burner's further startup sequence (and on subsequent burner operation):

- t5 Interval
- On completion of «t5», power is fed to terminal 20; at the same time, control outputs 9...11 and input 8 are galvanically separated from the unit's control section
 - The LFL1... is now protected against return voltages from the power control loop
 - The startup sequence of the LFL1... ends with the release of «LR» at terminal 20
 - After a number of idle steps (steps with no change of the contact position), the sequence switch switches itself off

Direct spark flame burners

- TSA Ignition safety time
On completion of «TSA», a flame signal must be present at terminal 22. It must not be interrupted until controlled shutdown takes place → otherwise lockout
- t3 Preignition time
Release of fuel via terminal 18
- t4 Interval «BV1 – BV2» or «BV1 - LR»
- On completion of «t4», terminal 19 is live
 - That powers «BV2» connected to the actuator's auxiliary switch «v»

Startup sequence (cont'd)

Interrupted pilot burners

- t3 Preignition time
t3' Release of fuel for pilot burner via terminal 17
- TSA Ignition safety time
TSA' On completion of «TSA», a flame signal must be present at terminal 22. It must not be interrupted until controlled shutdown takes place
→ otherwise non-volatile lockout
- t4 Interval «ZBV-BV1»
t4' Up to the release of the fuel valve at terminal 19 for the main burner's start load
- t9 Second safety time
On completion of the second safety time, the main burner must have been ignited by the pilot burner since terminal 17 becomes dead as soon as this time has elapsed, causing the pilot valve to close
- B Operating position of the burner
- B-C Burner operation
- During burner operation, «LR» drives the air damper to the high-fire or low-fire position, depending on the demand for heat
 - Release of high-fire is enabled by auxiliary switch «v» in the actuator
 - In the event of loss of flame during operation, the LFL1... will initiate lockout
- C Controlled shutdown
On controlled shutdown, the «BV...» will immediately be closed. At the same time, the sequence switch starts and programs «t6»
- C-D The sequence switch travels to start position «A», postpurging
When burner off time starts, control terminals 11 and 12 carry voltage to drive the air damper to the fully CLOSED position. Flame signal supervision also remains active during burner off times
- t6 Postpurge time
- Fan «M2» connected to terminal 7
 - Shortly after the start of «t6», power is fed to terminal 10
→ air damper will be driven to the MIN position
 - Full closing of the air damper starts only shortly before «t6» has elapsed
→ triggered by the control signal at terminal 11
 - During the following burner off period, terminal 11 remains live
- t13 Permissible afterburn time
During «t13», the flame signal input can still receive a flame signal
→ no lockout
- D-A End of control sequence
→ start position
As soon as the sequence switch has reached the start position – thereby switching itself off – the flame detector and extraneous light test will start again.
During burner off periods, the flame supervision circuit is live. A faulty flame signal of a few seconds will initiate lockout.
Short ignition pulses of the UV tube, caused for instance by cosmic radiation, do not lead to lockout.

Times «TSA'», «t3'» and «t4'» only exist with burner controls of the 01 series.

Control sequence under fault conditions and lockout indication

In the event of any kind of fault, the sequence switch will stop and, with it, the lockout indicator.

The symbol above the indicator's reading mark gives the type of fault:

◀	No start	<ul style="list-style-type: none"> • One of the contacts is not closed (also refer to «Preconditions for burner startup») • Extraneous light <p>Lockout during or after completion of the control sequence.</p> <p>Examples:</p> <ul style="list-style-type: none"> – Flames that have not extinguished – Leaking fuel valves – Defect in the flame supervision circuit
▲	Interruption of startup sequence	<ul style="list-style-type: none"> • Terminal 8 has not received the OPEN signal from end switch «a» • Terminals 6, 7 and 14 remain live until the fault has been corrected
P	Lockout	<ul style="list-style-type: none"> • No indication of air pressure at the beginning of the air pressure check • Loss of air pressure after the air pressure check
■	Lockout	<ul style="list-style-type: none"> • Defect in the flame supervision circuit
▼	Interruption of startup sequence	<ul style="list-style-type: none"> • Terminal 8 has not received the positioning signal from auxiliary switch «m» for the low-fire position • Terminals 6, 7 and 14 remain live until the fault has been corrected
1	Lockout	<ul style="list-style-type: none"> • No flame signal on completion of safety time «TSA»
2	Lockout	<ul style="list-style-type: none"> • No flame signal on completion of the second safety time (flame signal of main flame with interrupted pilot burners)
I	Lockout	<ul style="list-style-type: none"> • Loss of flame signal during operation

If lockout occurs any other moment in time between start and preignition not indicated by a symbol, the usual cause is a premature flame signal, that is, a faulty flame signal, caused for instance by a self-igniting UV tube.

Lockout indicator



LFL1... Series 01



LFL1... Series 02

- a-b Startup sequence
- b-b' Idle steps (with no contact confirmation)
- b (b')-a Postpurge program

- If lockout occurs, the burner control can immediately be reset:
 - Do not press the lockout reset button for more than 10 seconds
- The sequence switch always returns to its start position first
 - After resetting
 - After correction of a fault which resulted in plant shutdown
 - After each power failure

During that period of time, power is only fed to terminals 7 and 9...11.
- Then, the LFL1... begins with a new burner startup sequence

Connection diagrams (for circuit variants, refer to «Connection examples»)

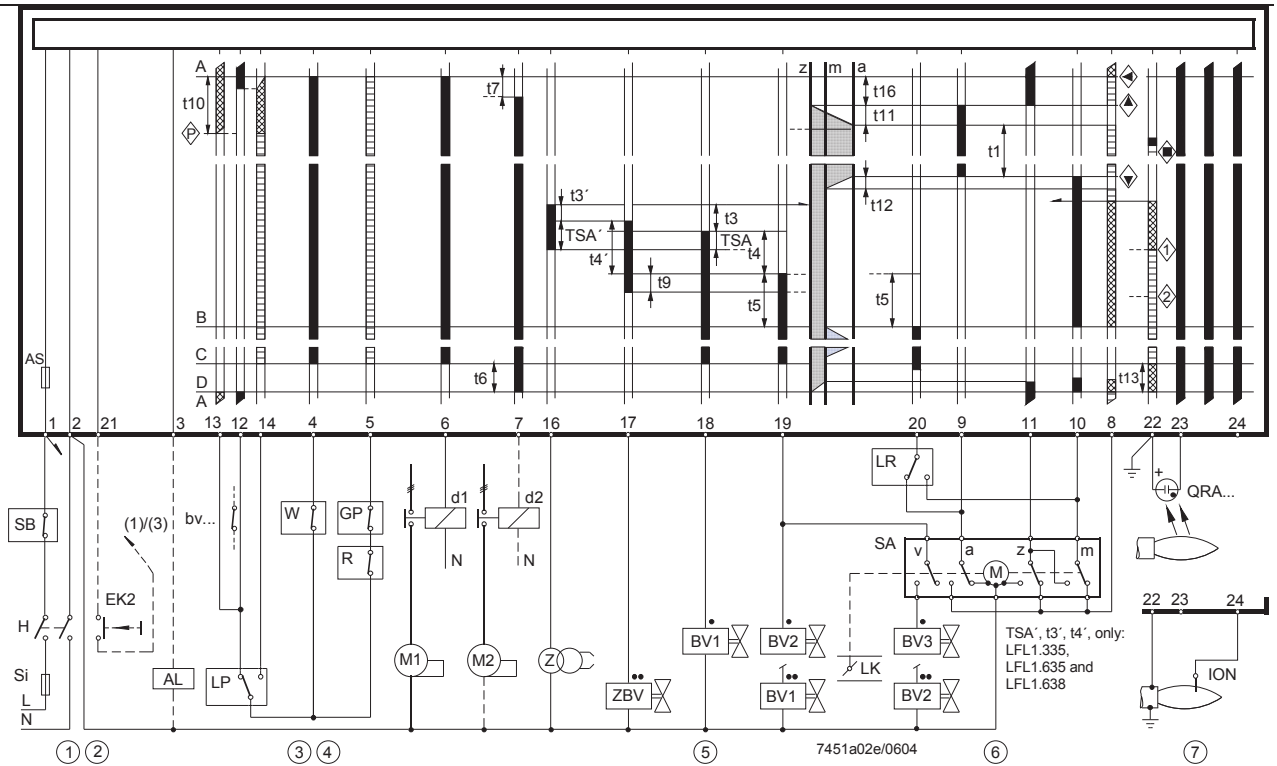

Connection diagram (for circuit variants, refer to «Connection examples»)

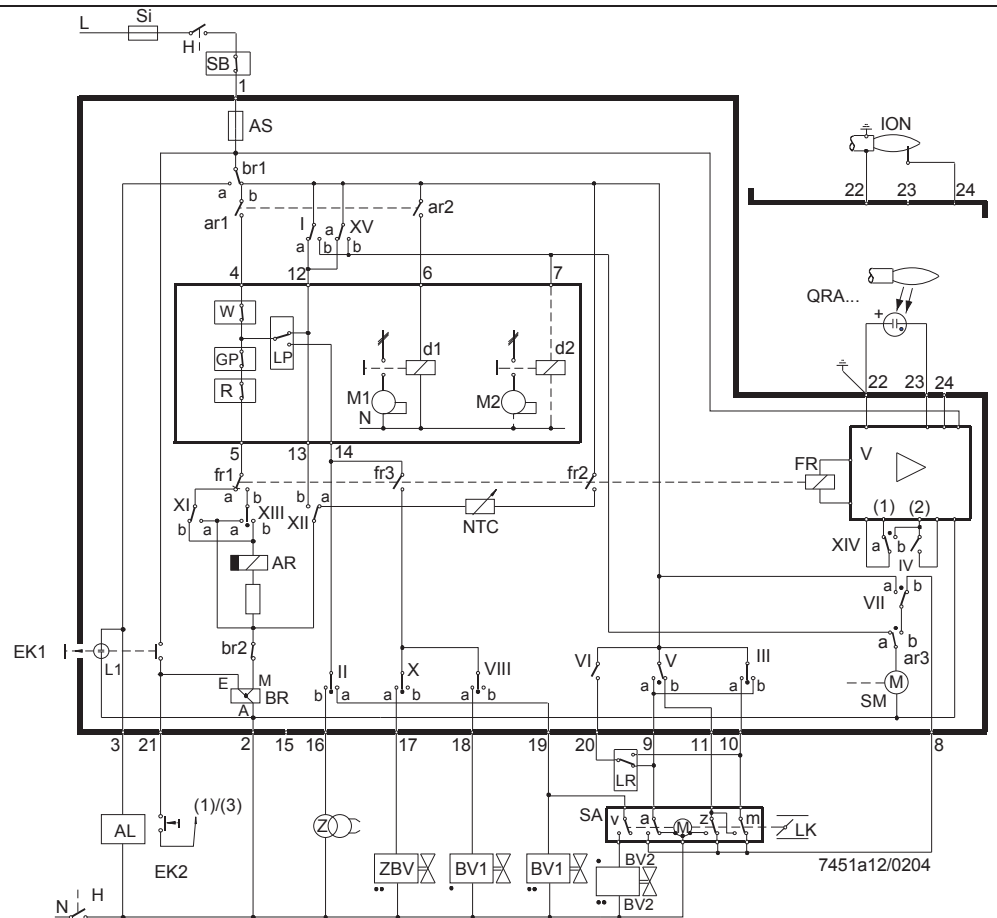

Attention!

Do not press lockout reset button «EK...» for more than 10 seconds!
For the connection of the safety shutoff valve, refer to the plant diagram provided by the burner manufacturer.

Program sequence

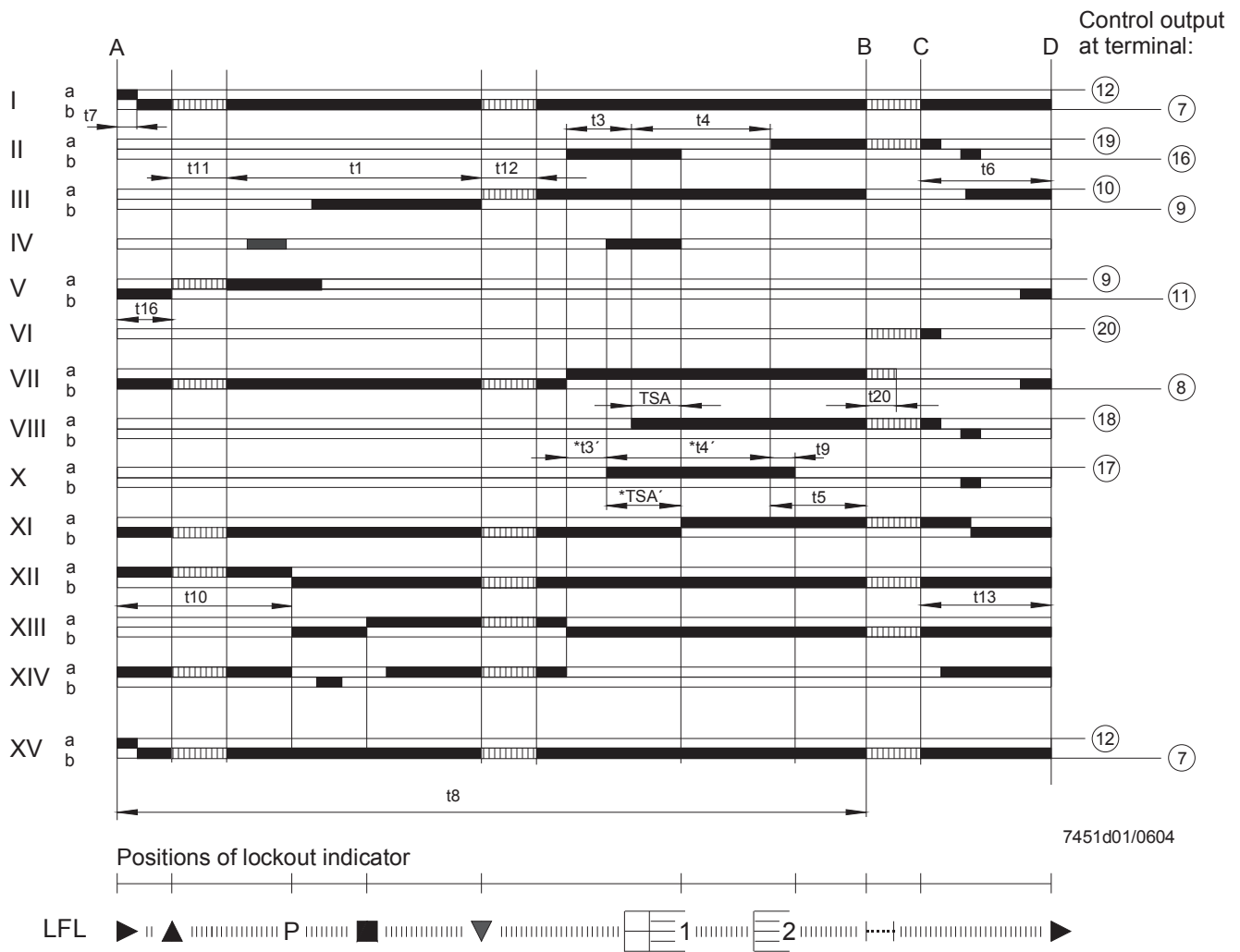

«TSA'», «t3'» and «t4'»:

These times only apply to burner controls of the 01 series (LFL1.335, LFL1.635, and LFL1.638). They do not apply to burner controls of the 02 series since cams X and VIII of these types of LFL1... perform simultaneous switching actions.



Legend

a	Changeover end switch for air damper's OPEN position	m	Changeover auxiliary switch for the air damper's MIN position
AL	Remote lockout warning device (alarm)	M...	Fan or burner motor
AR	Load relay with contacts «ar...»	NTC	NTC resistor
AS	Unit fuse	QRA...	UV detector
BR	Lockout relay with contacts «br...»	R	Control thermostat or pressurestat
BV...	Fuel valve	RV	Modulating fuel valve
bv...	Control contact for the CLOSED position of gas valves	Si	External fuse
d...	Contact or relay	SA	Air damper actuator
EK...	Lockout reset button	SB	Safety limiter
FR	Flame relay with contacts «fr...»	SM	Synchronous motor of sequence switch
GP	Gas pressure switch	v	In the actuator: Changeover auxiliary switch For the position-dependent release of fuel
H	Main isolator	V	Flame signal amplifier
ION	Ionization probe	W	Limit thermostat or pressure switch
L1	Fault signal lamp	z	In the actuator: End switch for the air damper's CLOSED position
L3	Operational readiness indication	Z	Ignition transformer
LK	Air damper	ZBV	Pilot gas valve
LP	Air pressure switch		
LR	Load controller		

 Control signals of the LFL1...

 Permissible input signals

 Required input signals:

If these signals are not present during  or , the burner control will interrupt the startup sequence or initiate lockout

TSA	Ignition safety time	t8	Duration of startup sequence (without «t11» and «t12»)
TSA'	Ignition safety time or first safety time (startup with burners using pilot burners)	t9	Second safety time with burners using pilot burners
t1	Prepurge time with air damper open	t10	Interval from start to the beginning of the air pressure check, excluding running time of air damper
t3	Preignition time	t11	Air damper running time to the OPEN position
t4	Interval between voltage at terminals 18 and 19	t12	Air damper running time to the low-fire position MIN
t4'	Interval between start of TSA' and release of valve at terminal 19	t13	Permissible afterburn time
t5	Interval between power at terminals 19 and 20	t16	Interval until OPEN command for the air damper is given
t6	Postpurge time (with «M2»)	t20	Interval to the self-shutdown of the sequence switch after startup
t7	Interval between start command and power at terminal 7 (start delay for «M2»)		

- Valid for direct spark flame burners
- Valid for interrupted pilot burners
- (1) Input for increasing the operating voltage for the QRA... (detector test)
- (2) Input for forced energizing of the flame relay during the functional test of the flame supervision circuit (contact XIV) and during safety time «TSA» (contact IV)

Connection examples

Doubling the safety time with direct spark flame burners

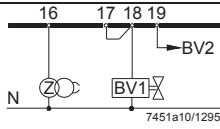

Only with burner controls of the 01 series.

This circuit change (linking terminals 17 and 18) reduces the preignition time by 50 %.

Extension of the safety time is only permitted if in compliance with the relevant national standards.

Burner without air damper

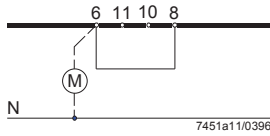

If the case of burners with no air damper (or with an air damper not controlled and monitored by the burner control), terminals 8 and 6 must be linked, as otherwise the burner control will not be able to start the burner.

Reversed polarity protection with AGM30

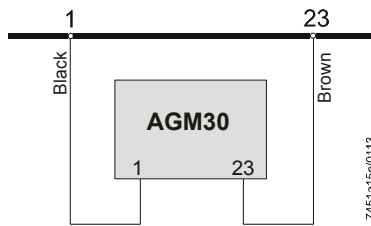

If the mains cables (L-N) are switched, the AGM30 simulates a flame signal (extraneous light). The burner initiates lockout.

2-stage direct spark flame burner

Load control by a 2-position controller. The air damper is closed during burner off periods.

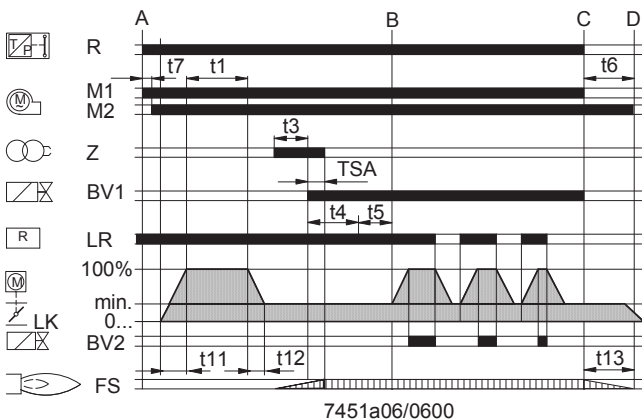
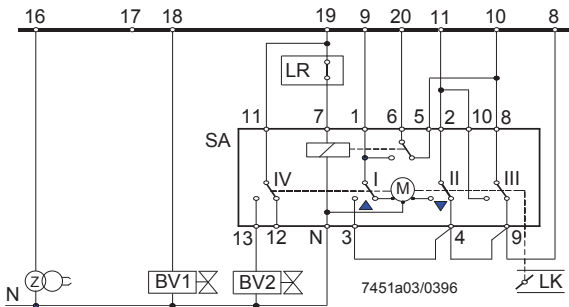
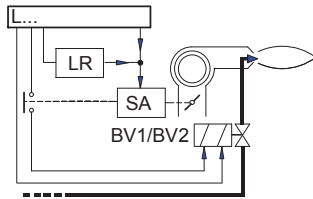

Control of actuator «SA» according to the single-wire principle (actuator «SA»: E.g. SQN3... according to Data Sheet N7808). For other connections, refer to «Connection diagrams».

Connection examples (cont'd)

Modulating direct spark flame burner

Load control by a modulating controller with galvanically separated control contacts for the positioning directions OPEN or CLOSE.

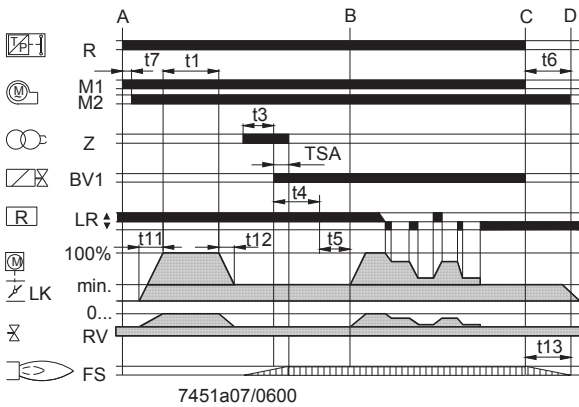
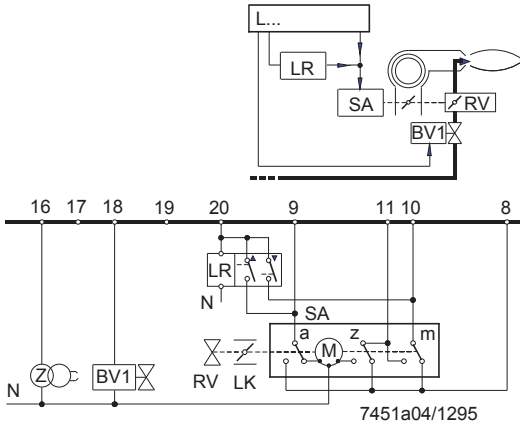

The air damper is kept closed during burner off periods. For other connections, refer to «Connection diagrams».

2-stage interrupted pilot burner (burner with pilot burner)

Controlled and supervised by a burner control of the 01 series.

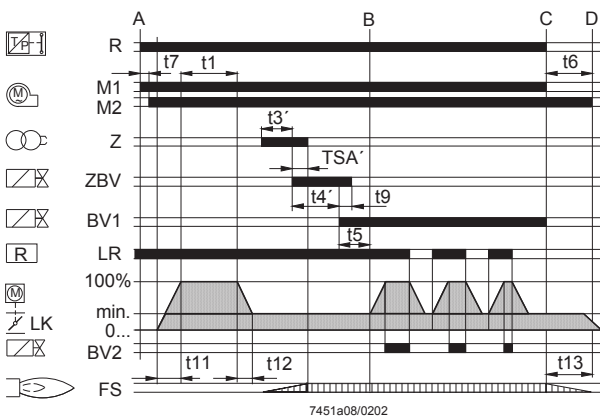
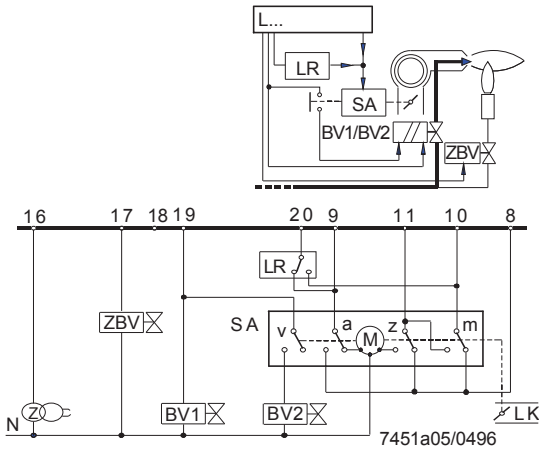

The air damper is kept closed during burner off periods. For other connections, refer to «Connection diagrams».

Dimensions

Dimensions in mm

LFL1...

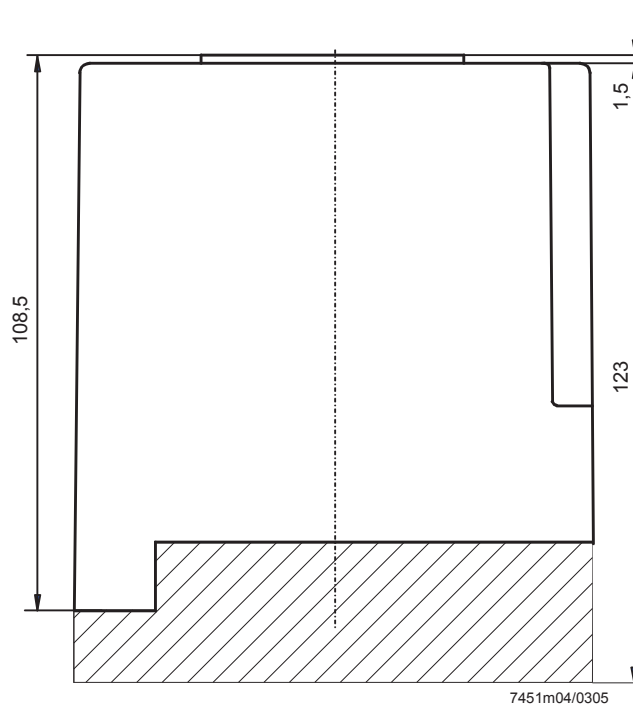

Plug-in base AGM410490550 /
AGM14.1

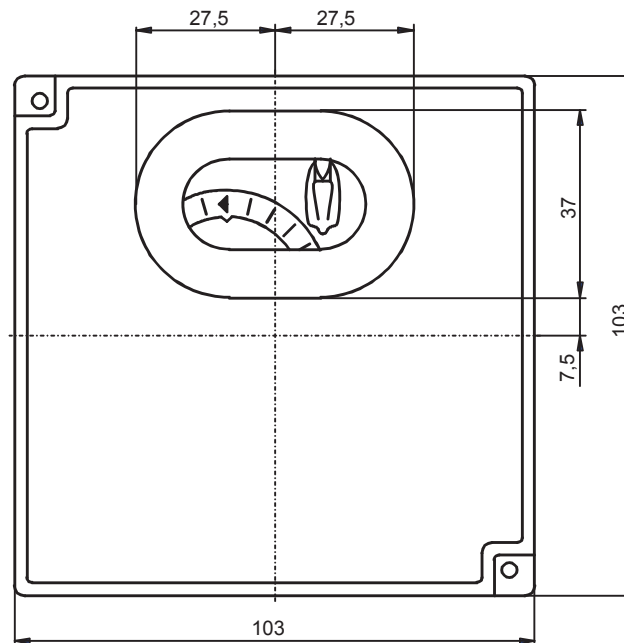

Distributeur: FLAME POWER SRL 021-3121727 ; 0744-340566 contact@arzatoare.ro ; www.arzatoare.ro

©2013 Siemens AG Infrastructure & Cities Sector Building Technologie Division
Subject to change!